

CMS Removable Proximity Probe Mount

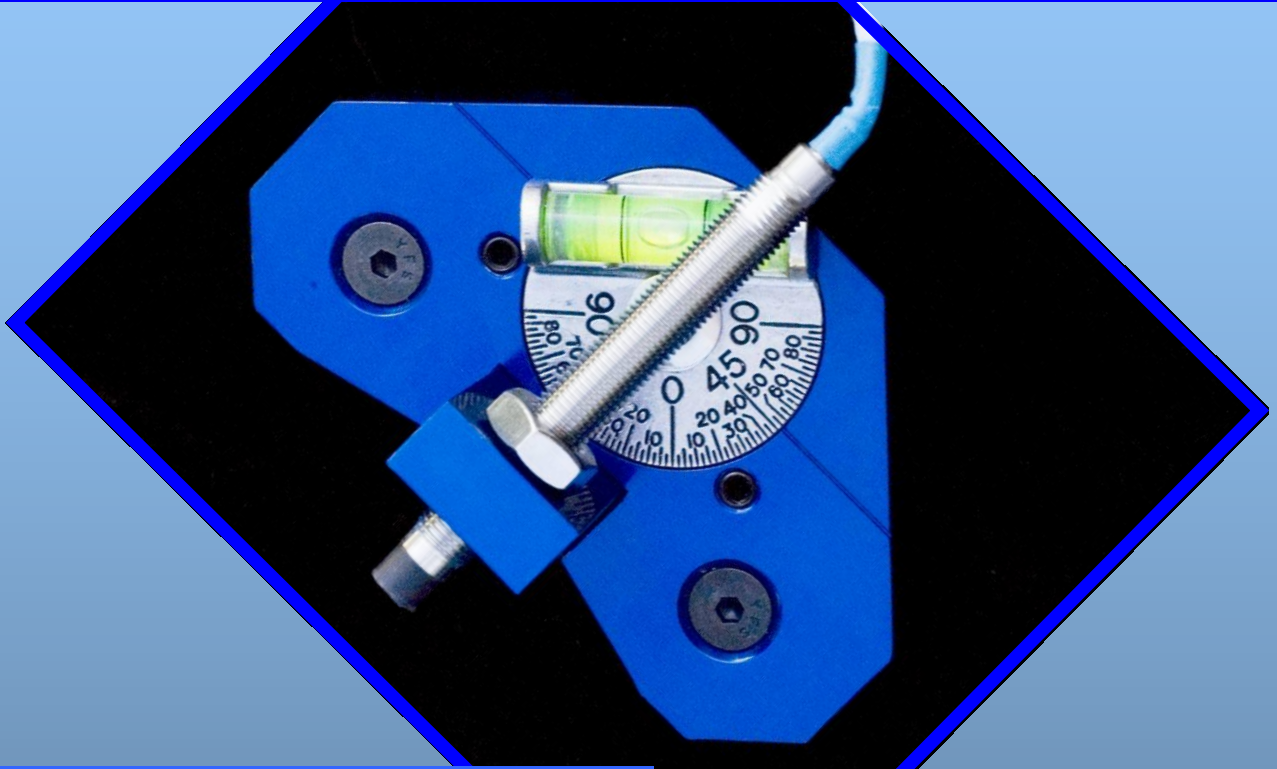

Photos show CTC Eddy Current Probes which are not included with Item 5050 Probe Holders but are included with Item 5068 Probe Holders & Power Supply.



MOUNTS

CONCEPT: The concept is to provide Mounts that permit temporary magnetic mounting of proximity probes (also called eddy current probes) to a standard sleeve bearing housing such as a Dodge Sleeveoil type. Temporary mounting of proximity probes is useful when diagnosing shaft motion (vibration or displacement) of the shaft relative to the bearing housing of fluid film bearings.

It is preferable to permanently install proximity probes on rotating machinery using either internal or external probe mounting procedures. However, due to both the cost and time typically involved to permanently install proximity probe systems, it is not always practical or feasible to do so. This device is intended to be used for temporary or short duration mounting of proximity probes permitting the accurate measurement of relative shaft vibration.

DESCRIPTION: The CMS Proximity Probe Mount uses two rare earth flat magnets to hold the body securely to the face of the bearing or seal housing. A movable level with protractor angle gauge allows positioning of the Mount body to the desired angle (such as 45 degrees). Two jacking screws are provided as aids to overcoming the strong magnetic force when positioning the Mount on the bearing housing or aid in removal from the bearing housing. Other machined surfaces are provided on the body of the probe Mount for use with a bubble level to help orient to the desired angular position.

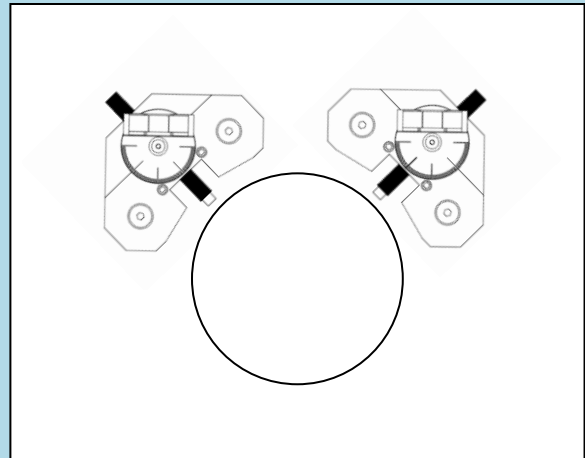

Figure 1. Probe Mounts Positioned at 90 Right (X) and 0 Deg (Y) at Top Dead

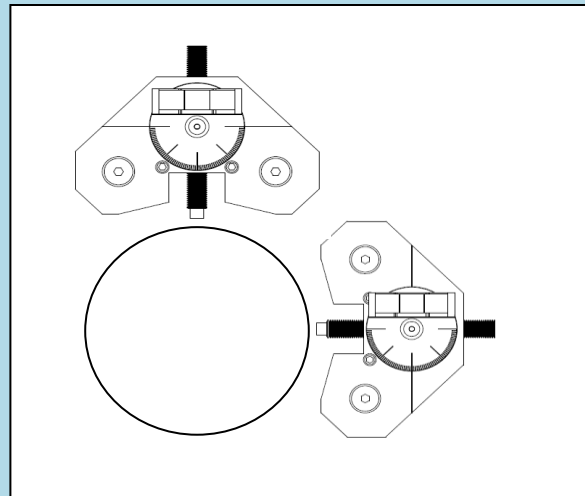

Figure 2. Probe Mounts Positioned at 90 Deg Right and Top Dead Center.



Figure 3. CMS Removable Probe Mount.

Retaining Bolts for the Magnets

Adjustable Level with Protractor Angle Gauge Provides for Accurate Angular Positioning.

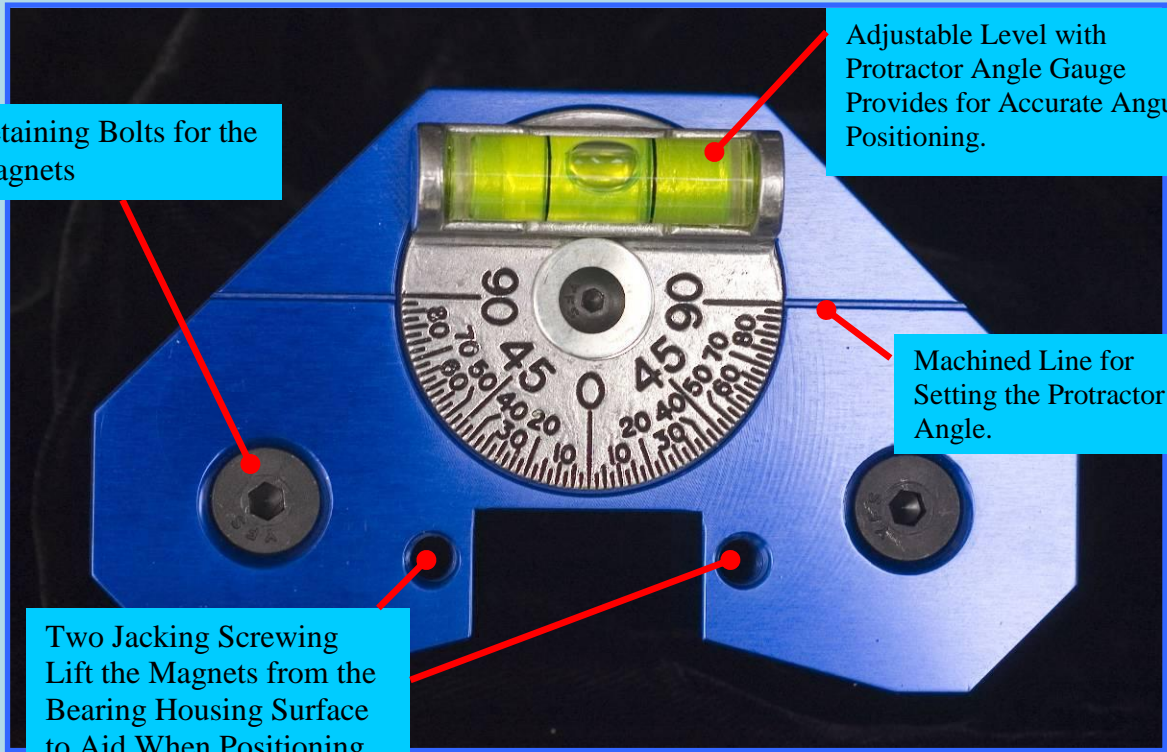

Machined Line for Setting the Protractor Angle.

Two Jacking Screws Lift the Magnets from the Bearing Housing Surface to Aid When Positioning and Removal From the Bearing Housing.

Extension Brackets are retained by Three Bolts.

Extension Brackets in Two Lengths Provide for Setting Probes Different Distances From the Bearing Housing.

Two 50 lb_f Rare Earth Magnets Hold the Mount Body Firmly to Bearing Housing.

Anodized Aluminum Construction for Lightweight and Corrosion Resistance.

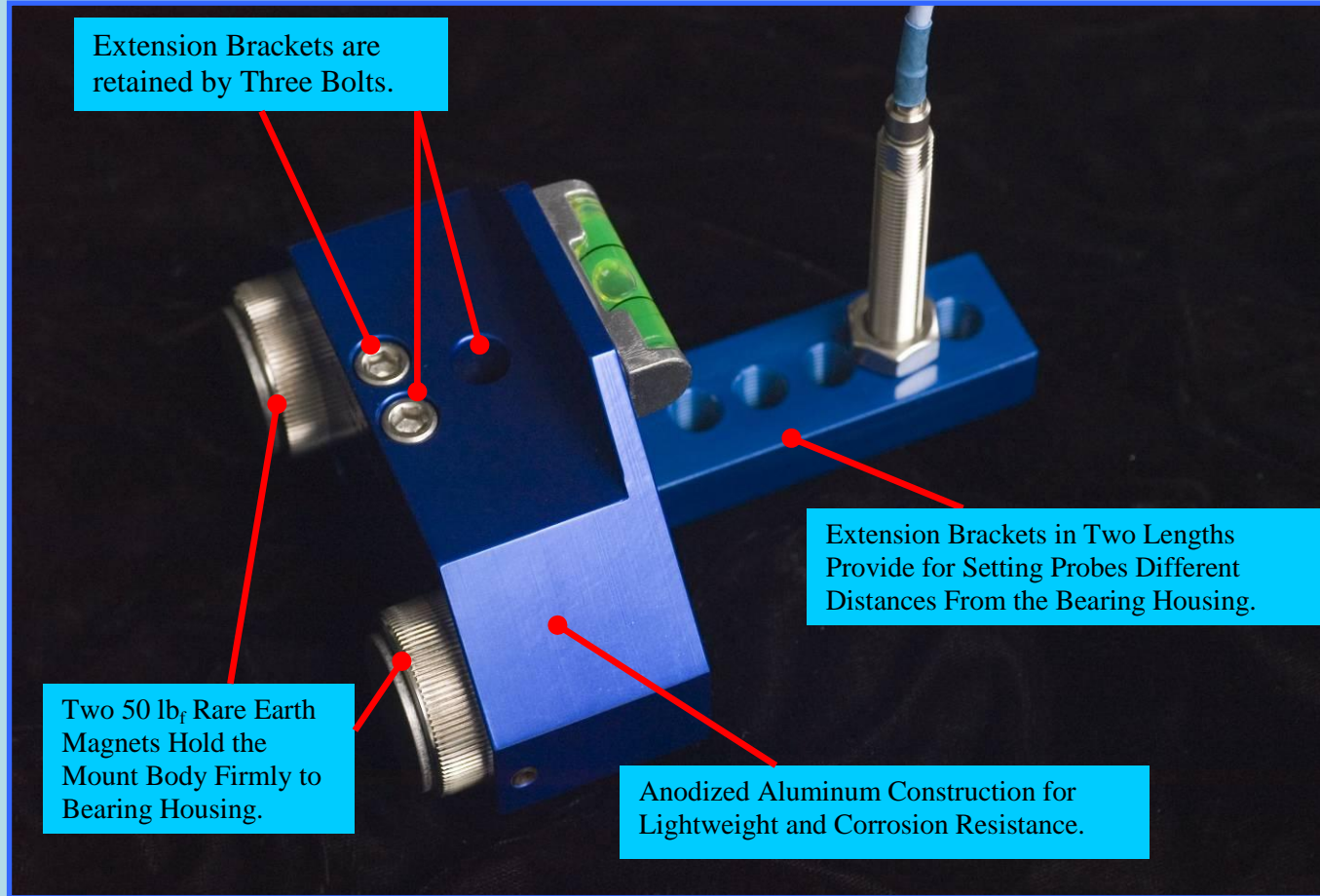

Application: Proximity Probe Displacement Measurements on ID Fan

The customer wanted to measure the displacement of the ID Fan Shaft at both bearings. The journals were supported by Dodge Sleeve Bearings. The CMS Movable Probe Holders were selected and attached using the integral rare earth magnets 90 degrees apart as shown in the photos. A laser tachometer was used to generate a once-per-revolution signal sensing white paint on the shaft. The data was measured and orbit at the drive end indicated vertical misalignment between the fan shaft and the fluid coupling.

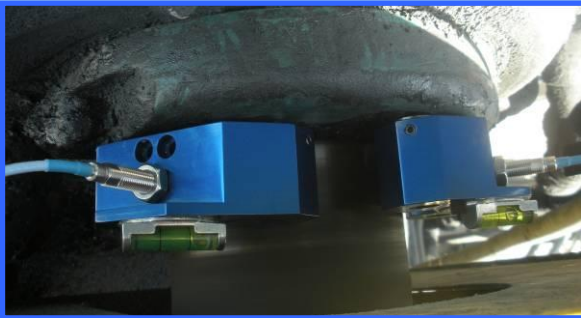

Figure 4. Removable Probe Mounts Attached to the Fan IB Bearing Housing.



Figure 5. Induced Draft Fan Outboard Bearing Housing Showing The Removable Probe Mounts at 45 Degrees Left and Right of Top Dead Center.



Figure 6. Removal Probe Mounts Attached to OB Bearing Housing of an ID Fan. Very Little Clearance is Needed to Install the Probe Mounts.

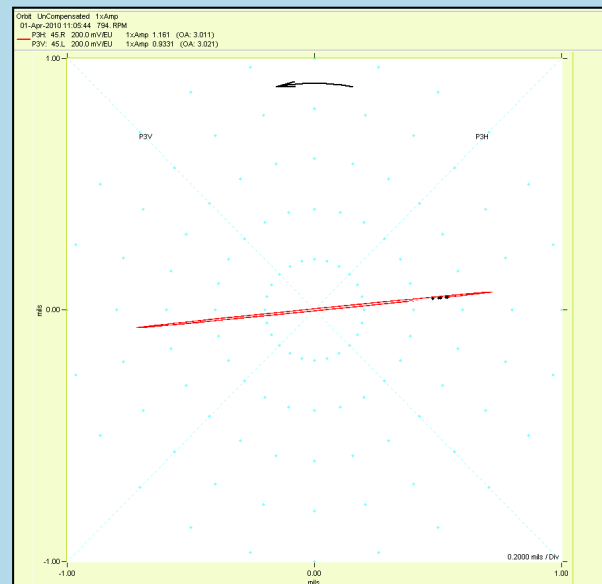

Figure 7. Induced Draft Fan IB Bearing. Flat Orbit is Indication of External Preload from Shaft Misalignment.

Attaching the removable proximity probe mounts to the bearing housings of a machine is first part of the setup to measure shaft displacement data. Proximity probes, extension cables and probe drivers are also required. The probe driver (proximitor) requires -24 VDC. Such a system can be provided by CMS that utilizes a NEMA enclosure with CTC proximity probe drivers, 120VAC/-24VDC power supply and CTC Extension Cables.

A typical application is shown by the schematic in Figure 8. Two Removable Probe Mounts (X & Y) are mounted on each bearing of a machine. Probe extension cables are then connected to the probe cables and to the probe drivers which are housed in the NEMA enclosure. The probe drivers are powered by a -24V DC power supply which is connected to 120VAC power.

Shaft displacement data is measured from the BNC's on the Probe Drivers. Typically a multi-channel data acquisition system is used to record the data. Data acquisition time may be for a few minutes, hours or several days depending on the circumstances.

In some situations, a two channel spectrum analyzer that is capable of generating orbit data can also be used. This would be applicable if only the orbit data from the shaft were needed to help diagnose a problem and not data during a transient event such as a coastdown or startup.

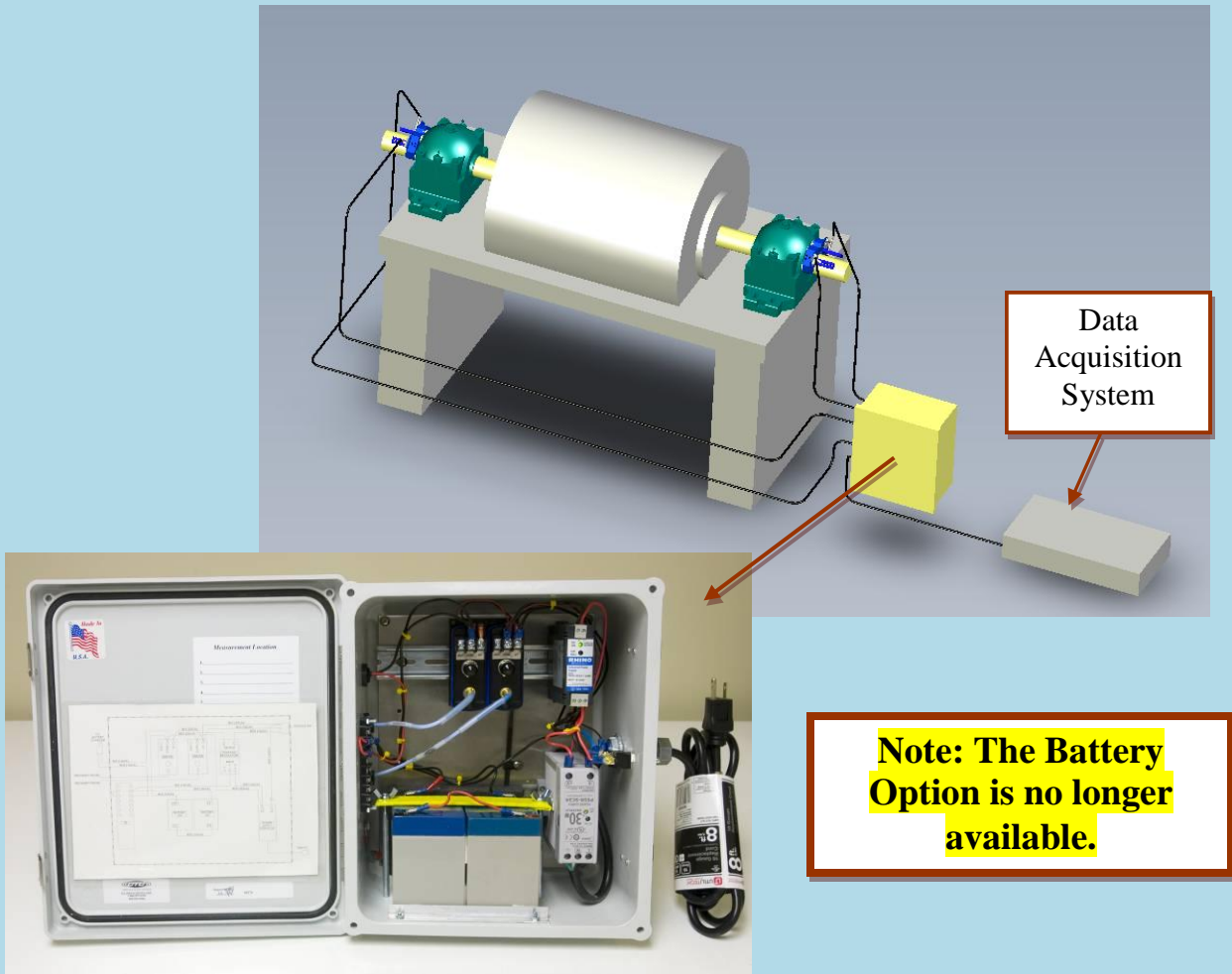

Figure 8. Proximity Probes Can be Powered From Drivers In the NEMA Enclosure by 120VAC/-24DC Power Supply or Optional -24VDC Battery Supply.

Application: Proximity Probe Displacement Measurements on Vertical Pump Shaft

The customer wanted to measure the displacement of the vertical pump shaft just below the bearing housing. The CMS Removable Probe Mounts were selected and attached using the integral rare earth magnets 90 degrees apart as shown in the photo. The customer reported he was very pleased with Probe Holders and they were successful in making the shaft measurements.

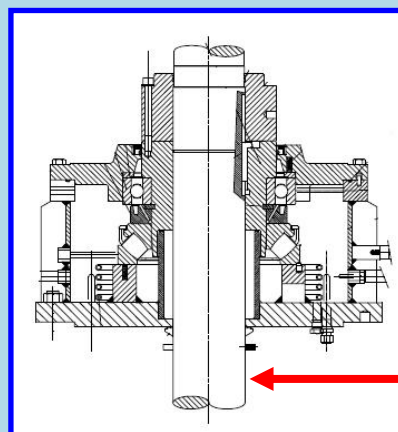

Figure 9. Customer mounted X/Y Proximity Probes Mounted on a Vertical Pump to Measure Shaft Displacement and Runout.

Applications:

Machines with Fluid Film Bearings, Shaft Vibration Relative to Bearing Housing

- **Induced Draft Fans**
- **Forced Draft Fans**
- **Process Fans**
- **Shaft Probe Track Runout Measurements in Test Stand or Balance Machine**
- **Vertical Pump Shaft Runout Measurements**
- **Steam Turbines**
- **Gearboxes**
- **Motors**